

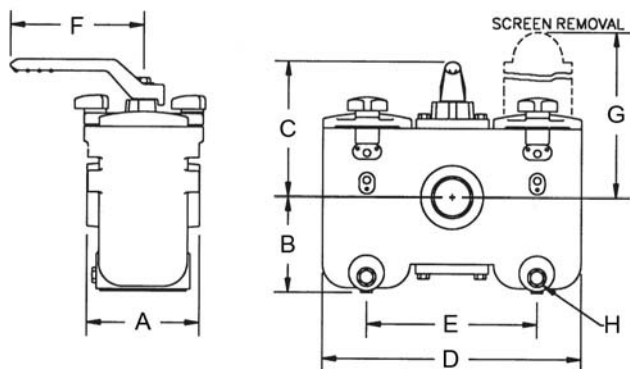

DIT

Duplex Cast Iron Threaded Strainers



PARTS LIST

| ITEM | DESCRIPTION | MATERIAL |
|------|----------------|-------------------------------------|
| 1 | BODY | CAST IRON (ASTM A 126, CLASS B) |
| 2 | DIVERTER | BRONZE (OPTIONAL: IRON OR ST STEEL) |
| 3 | BASKET SCREENS | STAINLESS STEEL |
| 4 | SEALS | NITRILE (-30F TO 250F) |

Non-Shock Working Pressure
Water, Oil, Gas: 200psi @150F

DIMENSIONS & WEIGHT

| SIZE (in) | A (in) | B (in) | C (in) | D (in) | E (in) | F (in) | G (in) | H (in) | WT (lbs) |
|-----------|--------|--------|--------|---------|---------|--------|----------|--------|----------|
| 3-4 | 4-3/4 | 4-1/8 | 5-7/8 | 10-5/8 | 6-11/16 | 6-7/8 | 8-11/16 | 1/2 | 29 |
| 1 | 4-3/4 | 4-1/8 | 5-7/8 | 10-5/8 | 6-11/16 | 6-7/8 | 8-11/16 | 1/2 | 29 |
| 1-1/4 | 5-3/8 | 5-3/8 | 6-7/8 | 11-3/16 | 7-1/4 | 6-7/8 | 12 | 1/2 | 42 |
| 1-1/2 | 5-3/8 | 5-3/4 | 6-7/8 | 11-3/16 | 7-1/4 | 6-7/8 | 12 | 1/2 | 42 |
| 2 | 7-1/4 | 6-1/8 | 8-3/4 | 16-3/4 | 11 | 8-1/4 | 13-13/16 | 1/2 | 108 |
| 2-1/2 | 7-1/4 | 6-1/8 | 8-3/4 | 16-3/4 | 11 | 8-1/4 | 13-13/16 | 1/2 | 108 |

CERTIFIED DIMENSIONAL SHEETS AVAILABLE

PRESSURE DROP MULTIPLIER FROM CLOGGING

Use separate chart to obtain unclogged pressure drop. Chart at right determines appropriate pressure drop multiplier for clogged screens.

Example: a 50% clogged screen would use a multiplier of 2.

